

1
2
3
4b
5
6
7
8
9
10
11

★★★★★ DIGI PLUS-LINE® Electr. Digital Test Indicator • IP65

- water- a. coolant proof acc. to DIN 40050 / IEC 60529 (IP65)
- with Sylvac electronic
- with data output RS232 „Power“

- data output RS232 combined with external power supply
- connection S_Connect Power USB / RS232 / (optional choice)
- mechanical parts in stainless, hardened, matt chrome finish
- housing and front panel made of polyamide
- LCD display with clear reading, digit height 6 mm, over 360° revolving
- autom. power off, zero setting at any position
- hold function, absolute and relative mode, input of preset value
- mm/inch switchable, selection of measuring direction
- housing with 3 dovetail guides
- incl. 1x 3 V battery (type CR2032, art.-no.: 2002093), with operation manual

Option

- data transfer via cable, art.-no. 2424101, see page 304

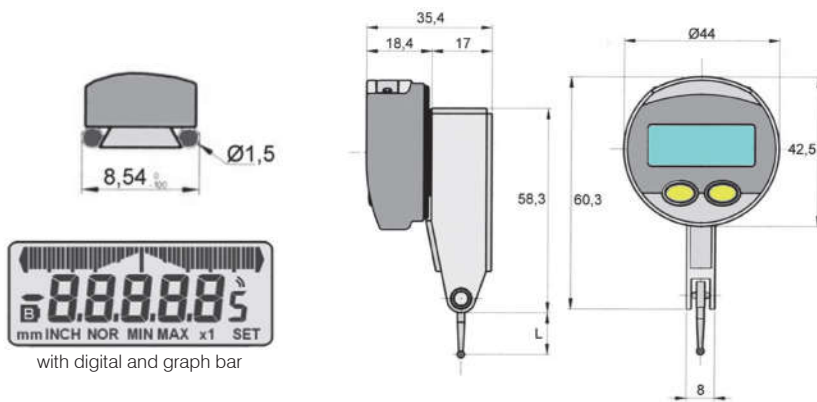

Accessories for our test indicators can be found on page 144

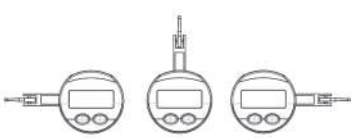

ART No	mm	mm / inch	measuring range mm / inch	mm	max. mm	measuring force N	L mm		ART No CC
240680	0 - 1.6	0.001 / 0.0001	±0.8 / ±0.03	0.001	0.01	0.13 ±15%	12.5	0.073	2494200
240681	0 - 1	0.001 / 0.0001	±0.5 / ±0.02	0.001	0.01	0.07 ±15%	36.5	0.075	2494200

★★★★★ BLUE-LINE® Crankshaft Testing Instruments

- for testing crankshaft deflections and for the alignment of crankshaft bearings during engine assembly
- used in ship engines, car engines, compressors, etc.



--	--	--	--

ART No	mm	mm	housing-ø of dial indicator mm		ART No CC
240162.2	80 - 530	0.01	40	1.200	2494000