

1  
2d  
3  
4  
5  
6  
7  
8  
9  
10  
11

## ★★★★★ BLUE-LINE Vernier Caliper for 3/5-Point-Measurements

ART N° 201070

• for measuring diameters of side-mills

- stainless steel, hardened
- scale and vernier satin chrome finish, laser engraved scale
- jaws finely ground
- with fixing screw
- mono-block vernier

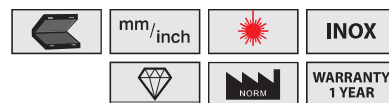
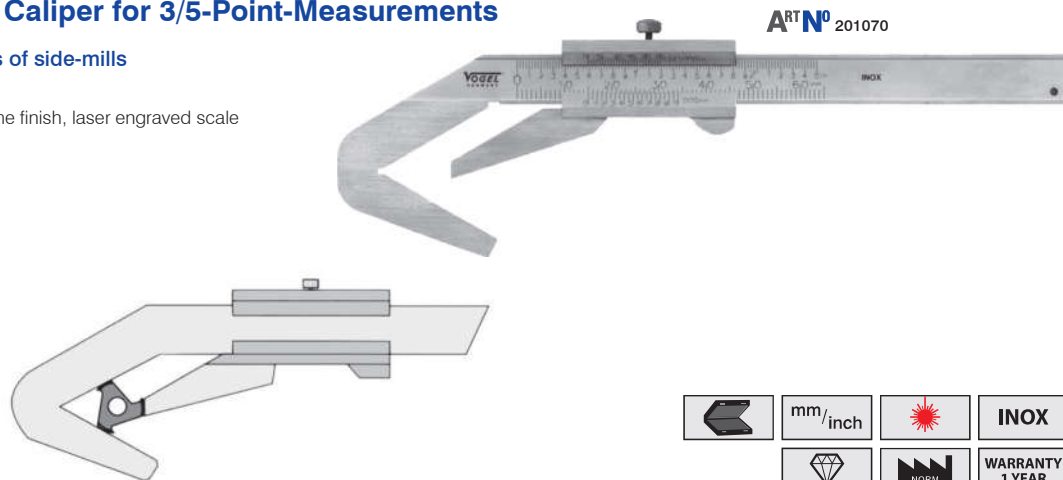

ART N° 3-point	ART N° 5-point	mm / inch	mm bottom	inch top	KG	ART N° CC
201070	-	4 - 40 / 0.16 - 1.60	0.05	1/128	0.180	2094070
-	201071	2 - 40 / 0.08 - 1.60	0.05	1/128	0.180	2094070

## ★★★★★ DIGI PLUS-LINE Electr. Digital Gear Teeth Caliper workshop grade

ART N° 202302

• to measure the gear teeth at front-and helical gears, etc.

- stainless steel, hardened
- LCD display with clear reading
- carbide jaws, finely ground
- with fixing screw and fine adjustment on both sides
- On/Off button, zero setting at any position
- mm/inch switchable
- incl. 1x 1.5 V battery (type LR44, art.-no.: 2020192/B), with operation manual

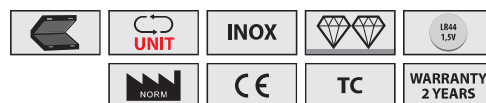
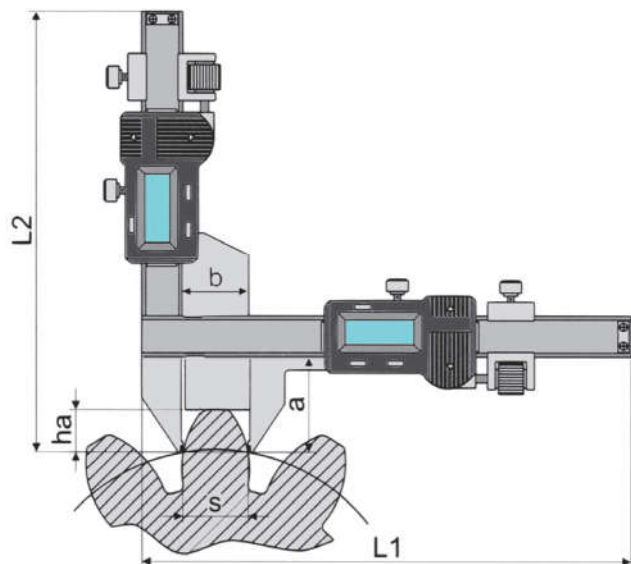

ART N°	modules	mm / inch	mm	max. mm	L1 mm	L2 mm	a mm	b mm	KG	ART N° CC
202301	m 1-25	0.01 / 0.0005	0.01	0.03	156	156	30.5	21	0.170	2094103
202302	m 5-50	0.01 / 0.0005	0.01	0.03	210	185.5	50.5	50.5	0.215	2094103