

SILVER-LINE® Workshop Caliper
DIN 862 or in special sizes
acc. to workshop grade

precision class

- stainless steel, hardened
- scale and vernier satin chrome finish, laser engraved scale
- jaws finely ground
- offset jaws for inside measurements
- with or without fine adjustment, with knife points
- with fixing screw
- mono block vernier
- up to 1000 mm in plastic case, other sizes in wooden case



ART N° 200602

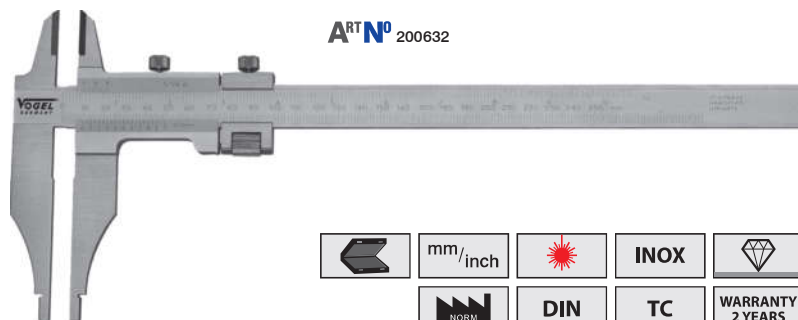

ART N° 200632

Spare parts and accessories
for our calipers can be found
on page 74+75

mm/inch
 INOX
 WARRANTY 2 YEARS
 NORM
 DIN
 TC

200601	200631	200 / 8	0.05	1/128	65	32	10	0.365	2094020
200602	200632	250 / 10	0.05	1/128	80	32	10	0.400	2094025
200603	200633	300 / 12	0.05	1/128	100	32	10	0.425	2094030
200604	200634	400 / 16	0.05	1/128	100	32	20	0.880	2094040
200605	200635	500 / 20	0.05	1/128	150	67	20	1.540	2094050
200606	200636	600 / 24	0.05	1/128	150	67	20	1.600	2094060
200608	200638	800 / 32	0.05	1/128	150	67	20	2.760	2094080
200610	200640	1000 / 40	0.05	1/128	150	67	20	3.260	2094100
200612*	200652*	1500 / 60	0.05	1/128	200	80	20	3.400	2094150
200613*	200653*	2000 / 80	0.05	1/128	200	80	20	7.120	2094200
200614*	200654*	2500 / 100	0.05	1/128	200	80	20	9.150	2094250
200615*	200655*	3000 / 120	0.05	1/128	200	80	20	9.460	2094300
200616*	200656*	3000 / 120	0.05	1/128	300	80	20	9.650	2094300
200617*	200657*	3500 / 140	0.05	1/128	200	80	20	11.000	2094350
200618*	200658*	3500 / 140	0.05	1/128	300	80	20	11.200	2094350

1
2c
3
4
5
6
7
8
9
10
11